

## Cast Steel OS&Y Globe Valve to DIN PN25-F1, DN50~DN150

## Series GBF-PN25-F1

### Features

- Cast steel body construction providing liberal strength to meet most conditions
- Integral yoke & bonnet; outside screw & yoke, bolted bonnet
- Seal welded seat ring eliminates leak path behind rings and for long trouble-free service
- Available in flanged end connection; butt weld ends also available
- EN10204-3.1 Material certificate available

PMA: 25 barg@50°C

TMA: 450°C

Selection:

Material of Body:  
DIN 17245 GS-C25

### Standards

- Basic design to DIN 3356
- Face-to-face acc. to DIN 3202-F1
- End flange dimension acc. to EN 1092-1
- Inspection & test acc. to EN 12266-1

### Note

- For non-horizontal installation, please ensure to consult with us separately, as special request must be generated to ensure proper function.

Materials List		
No.	PARTS NAME	MATERIALS
1	BODY	DIN 17245 GS-C25 + 13Cr
2	DISC	ASTM A105 +13Cr
3	STEM	ASTM A182 F6a
4	DISC BONNET	AISI 1025
5	BONNET BOLT	ASTM A193 B7
6	BONNET NUT	ASTM A194 2H
7	GASKET	SS304+FLEXIBLE GRAPHITE
8	BONNET	DIN 17245 GS-C25
9	STEM PACKING	FLEXIBLE GRAPHITE
10	GLAND EYEBOLT	ASTM A193 B7
11	GLAND NUT	ASTM A194 2H
12	PIN	AISI 1025
13	GLAND FLANGE	DIN 17245 GS-C25
14	STEM NUT	COPPER ALLOY
15	GRUP SCREW	CARBON STEEL
16	HANDWHEEL	DUCTILE IRON
17	LOCK NUT	ASTM A194 2H

\* Enclosed is a condensed table. For complete options, contact DIE ERSTE directly.

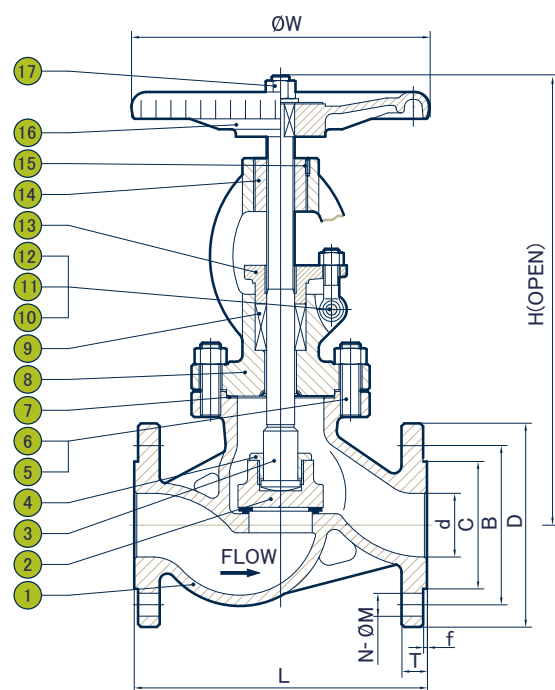

### Dimensions (mm)

Size		d	D	B	C	W	L	H	T	f	N	M
DN	IN											
50	2"	50	165	125	102	200	230	325	20	3	4	18
65	2½"	65	185	145	122	220	290	385	22	3	8	18
80	3"	80	200	160	138	250	310	410	24	3	8	18
100	4"	100	235	190	162	300	350	455	24	3	8	22
125	5"	125	270	220	188	350	400	510	26	3	8	26
150	6"	150	300	250	218	400	480	560	28	3	8	26

# Cast Steel OS&Y Globe Valve to DIN PN25-F1, DN200~DN300

## Series GBF-PN25-F1

### Features

- Cast steel body construction providing liberal strength to meet most conditions
- Integral yoke & bonnet; outside screw & yoke, bolted bonnet
- Seal welded seat ring eliminates leak path behind rings and for long trouble-free service
- Available in flanged end connection; butt weld ends also available
- EN10204-3.1 Material certificate available

PMA: 25 barg@50°C

TMA: 450°C

Selection:

Material of Body:  
DIN 17245 GS-C25

### Standards

- Basic design to DIN 3356
- Face-to-face acc. to DIN 3202-F1
- End flange dimension acc. to EN 1092-1
- Inspection & test acc. to EN 12266-1

### Note

- For non-horizontal installation, please ensure to consult with us separately, as special request must be generated to ensure proper function.

DIE ERSTE reserves the right to change product design and specifications without notice. Copyright © 2022 by DIE ERSTE INDUSTRY CO., LTD.

#### 4 Materials List

No.	PARTS NAME	MATERIALS
1	BODY	DIN 17245 GS-C25 + 13Cr
2	BIG DISC	ASTM A105 +13Cr
3	SMALL DISC	ASTM A105 +13Cr
4	SMALL DISC NUT	ASTM A105
5	BIG DISC NUT	ASTM A105
6	STEM	ASTM A182 F6a
7	GASKET	SS304+FLEXIBLE GRAPHITE
8	BONNET BOLT	ASTM A193 B7
9	BONNET NUT	ASTM A194 2H
10	STEM PACKING	FLEXIBLE GRAPHITE
11	GLAND	ASTM A182 F6a
12	GLAND FLANGE	DIN 17245 GS-C25
13	SPLINTS	CARBON STEEL
14	BONNET	DIN 17245 GS-C25
15	BEARINGS	ALLOY STEEL
16	STEM NUT	ASTM A439 D2
17	RETAINING NUT	AISI 1025
18	HANDWHEEL	DUCTILE IRON
19	LOCK NUT	CARBON STEEL
20	NIPPLE	COPPER ALLOY
21	GLAND EYEBOLT	ASTM A193 B7
22	GLAND NUT	ASTM A194 2H
23	PIN	AISI 1025

\* Enclosed is a condensed table. For complete options, contact DIE ERSTE directly.

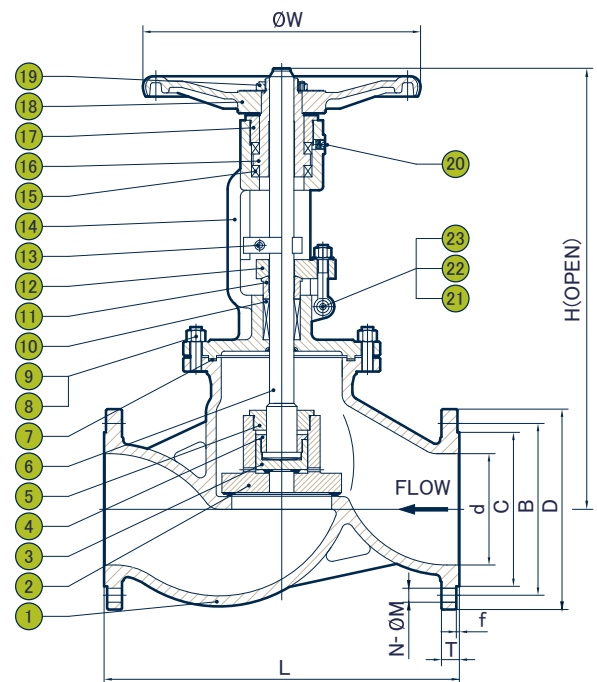

### Dimensions (mm)

Size		d	D	B	C	W	L	H	T	f	N	M
DN	IN											
200	8"	200	360	310	278	450	600	750	30	3	12	26
250	10"	250	425	370	335	500	730	932	32	3	12	30
300	12"	300	485	430	395	550	850	1036	34	4	12	30