

Cast steel OS&Y Gate Valve to DIN PN160-F7, DN50~DN150

Series GTF PN160-F7

Features

- Cast steel body construction providing liberal strength to meet most conditions
- Integral yoke & bonnet; Outside screw & yoke, bolted bonnet
- Single flexible wedge disc compensates for deformation of body due to pipe stresses
- Seal welded seat ring eliminates leak path behind rings and for long trouble-free service
- Available in flanged end connection; butt weld end also available

PMA: 160 barg@50°C

TMA: 425°C

Selection:

Material of Body:
DIN 17245 GS-C25

Standards

- Basic design to DIN 3352
- Face-to-Face acc. to DIN 3202-F7
- Flange Dimensions acc. to EN 1092-1
- Inspection & test according to EN 12266-1

Note

- For non-horizontal installation, please ensure to consult with us separately, as special request must be generated to ensure proper function.

Materials List		
No.	PARTS NAME	MATERIALS
1	BODY	DIN 17245 GS-C25 + 13Cr
2	WEDGE	DIN 17245 GS-C25 + 13Cr
3	STEM	ASTM A182 F6a
4	BONNET BOLT	ASTM A193 B7
5	BONNET NUT	ASTM A194 2H
6	GASKET	SS304+FLEXIBLE GRAPHITE
7	BONNET	DIN 17245 GS-C25
8	STEM PACKING	FLEXIBLE GRAPHITE
9	GLAND EYEBOLT	ASTM A193 B7
10	GLAND NUT	ASTM A194 2H
11	PIN	AISI 1025
12	GLAND FLANGE	DIN 17245 GS-C25
13	NIPPLE	COPPER ALLOY
14	STEM NUT	ASTM A439 D2
15	RETAINING NUT	AISI 1025
16	HANDWHEEL	DUCTILE IRON
17	LOCK NUT	AISI 1025
18	NUT	ASTM A194 2H
19	BOLT	ASTM A193 B7
20	STEM NUT	COPPER ALLOY
21	GEAR BOX	COMPONENTS

* Enclosed is a condensed table. For complete options, contact DIE ERSTE directly.

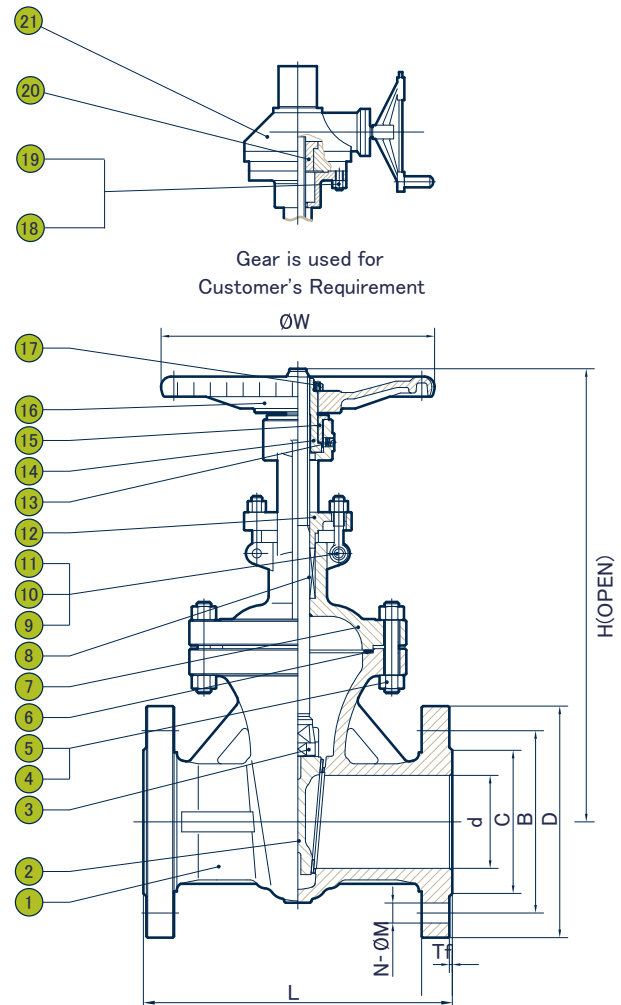

17

DIE ERSTE reserves the right to change product design and specifications without notice. Copyright © 2023 by DIE ERSTE INDUSTRY CO., LTD.

Dimensions (mm)

Size		d	D	B	C	W	L	H	T	f	N	M
DN	IN											
50	2"	50	195	145	102	220	250	440	30	3	4	26
65	2½"	65	220	170	122	250	290	480	34	3	8	26
80	3"	80	230	180	138	280	310	525	36	3	8	26
100	4"	100	265	210	162	300	350	625	40	3	8	30
125	5"	125	315	250	188	400	400	740	44	3	8	33
150	6"	150	355	290	218	450	450	810	50	3	12	33

Cast steel OS&Y Gate Valve to DIN PN160-F7, DN200~DN300

Series GTF PN160-F7

Features

- Cast steel body construction providing liberal strength to meet most conditions
- Integral yoke & bonnet; Outside screw & yoke, bolted bonnet
- Single flexible wedge disc compensates for deformation of body due to pipe stresses
- Seal welded seat ring eliminates leak path behind rings and for long trouble-free service
- Available in flanged end connection; butt weld end also available

PMA: 160 barg@50°C

TMA: 425°C

Selection:

Material of Body:
DIN 17245 GS-C25

Standards

- Basic design to DIN 3352
- Face-to-Face acc. to DIN 3202-F7
- Flange Dimensions acc. to EN 1092-1
- Inspection & test according to EN 12266-1

Note

- For non-horizontal installation, please ensure to consult with us separately, as special request must be generated to ensure proper function.

Materials List

No.	PARTS NAME	MATERIALS
1	BODY	DIN 17245 GS-C25 + 13Cr
2	WEDGE	DIN 17245 GS-C25 + 13Cr
3	STEM	ASTM A182 F6a
4	BONNET BOLT	ASTM A193 B7
5	BONNET NUT	ASTM A194 2H
6	GASKET	SS304+FLEXIBLE GRAPHITE
7	BONNET	DIN 17245 GS-C25
8	STEM PACKING	FLEXIBLE GRAPHITE
9	GLAND EYEBOLT	ASTM A193 B7
10	GLAND NUT	ASTM A194 2H
11	PIN	AISI 1025
12	GLAND FLANGE	DIN 17245 GS-C25
13	YOKE	DIN 17245 GS-C25
14	NIPPLE	COPPER ALLOY
15	STEM NUT	ASTM A439 D2
16	RETAINING NUT	AISI 1025
17	HANDWHEEL	DUCTILE IRON
18	LOCK NUT	AISI 1025
19	NUT	ASTM A194 2H
20	BOLT	ASTM A193 B7
21	STEM NUT	COPPER ALLOY
22	GEAR BOX	COMPONENTS

* Enclosed is a condensed table. For complete options, contact DIE ERSTE directly.

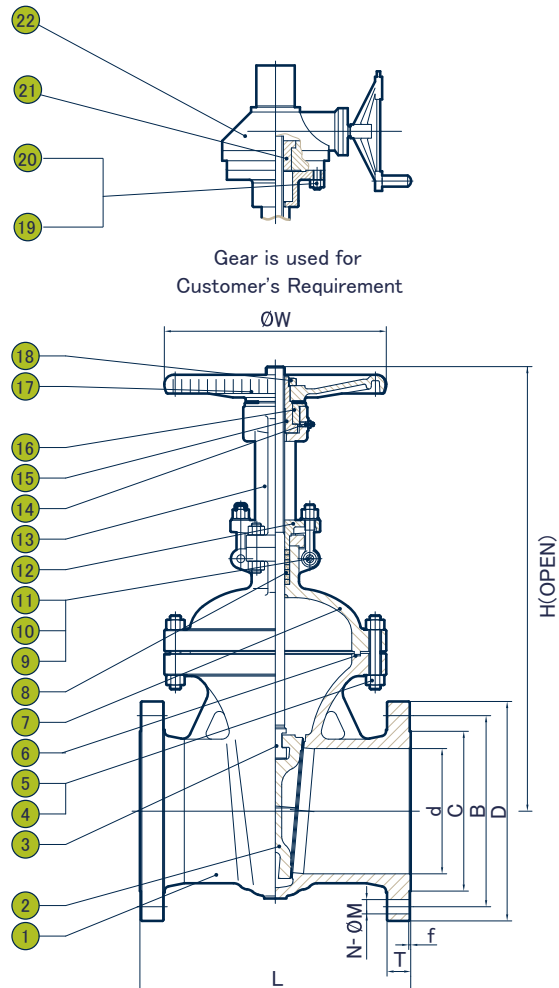

Dimensions (mm)

Size		d	D	B	C	W	L	H	T	f	N	M
DN	IN											
200	8"	200	430	360	285	400	550	1015	60	3	12	36
250	10"	250	505	430	345	450	650	1220	68	3	12	39
300	12"	300	585	500	410	500	750	1440	78	4	16	42