

Concentric Butterfly Valve to DIN/EN Wafer Type

PN10, DN40 ~ DN300

Series 81W(E)-PN10

Features

- Suitable for use in HVAC, irrigation, industrial applications where positive shutoff is required
- Single through-put shaft provides most economical pricing
- 10 position lever or gear operation
- Alloy material available on request

PMA: See Table A

TMA: See Table B

Selection:

Material of Body:
CF8M/CF8/CI/DI

Standards

- End dimensions acc. to DIN2633
- Inspection & test acc. to EN12266

Limitation

- Do not use EPDM when hydrocarbons are present.
- Kindly anticipate increased torque for PTFE coated disc + PTFE seat option; gear operation recommended for sizes $\geq 4"$.

Options

- Double "half pin" style available for increased performance and lifecycle
- Coated disc available in: rubber, PTFE, nylon

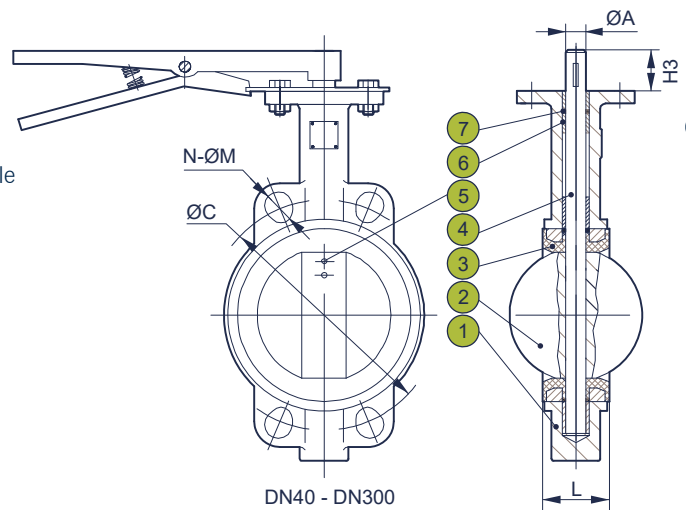
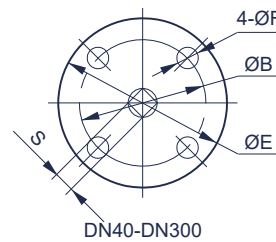

Materials List		
NO	PARTS NAME	MATERIAL
1	BODY	CF8M / CF8 / CI / DI
2	DISC*	CF8M / CF8 / CI / DI
3	SEAT	NBR / EPDM / VITON
4	STEM	SS410
5	TAPER PIN	SS
6	BUSHING	PTFE
7	O-RING	EPDM

*Coated disc option available.
Enclosed a condensed table, for complete options, contact DIE ERSTE directly.

Dimensions (mm)

Size		H1	H2	H3	L	ØD	ØC	N-ØM	ØA	ØE	ØB	ØF	S
IN	DN												
1½"	40	70	110	32	35	42.4	110	4-Ø18	12.7	92	70	9	9
2"	50	76	162	32	45	52.9	125	4-Ø18	12.7	92	70	9	9
2½"	65	89	175	32	48	64.6	145	4-Ø18	12.7	92	70	9	9
3"	80	95	181	32	49	79	160	4-Ø18	12.7	92	70	9	9
4"	100	114	200	32	55	104.4	180	8-Ø18	15.8	92	70	9	11
5"	125	127	213	32	58	129.5	210	8-Ø18	19	92	70	9	14
6"	150	140	225	32	59	155.8	240	8-Ø23	19	92	70	9	14
8"	200	177	260	36	64	202.7	295	8-Ø23	22.2	125	102	11	17
10"	250	203	292	36	70	250.7	350	12-Ø23	28.6	125	102	11	22
12"	300	242	337	36	80	301.9	400	12-Ø23	31.8	150	120	13	22

Table A: Maximum Pressure Rating

SIZE	RUBBER SEAT	PTFE SEAT	PTFE SEAT+ PTFE COATED DISC
≤DN150 (6")	13.7 bar (200psi)	13.7 bar (200psi)	10.3 bar (150 psi)
DN200 (8")	13.7 bar (200psi)	10.3 bar (150 psi)	10.3 bar (150 psi)
DN250 (10")~ DN300 (12")	13.7 bar (200psi)	10.3 bar (150 psi)	6.9 bar (100 psi)
DN350 (14")~ DN600 (24")	10.3 bar (150 psi)	6.9 bar (100 psi)	6.9 bar (100 psi)
≥DN600 (24")	6.9 bar (100 psi)	-	-
Gear Operation Recommendation	≥ 300	≥ DN150	≥ 100

Table B: Temperature Rating

SEAT	APPLICABLE TEMPERATURE
NBR	-20°C to +80°C (-4°F to 176°F)
EPDM	-20°C to +120°C (-4°F to 248°F)
VITON	-10°C to +200°C (+14°F to 392°F)
PTFE	-20°C to +150°C (-4°F to 302°F)

Concentric Butterfly Valve to DIN/EN Wafer Type

PN10, DN350 ~ DN1200

Series 81W(E)-PN10

Features

- Suitable for use in HVAC, irrigation, industrial applications where positive shutoff is required
- Single through-put shaft provides most economical pricing
- 10 position lever or gear operation
- Alloy material available on request

PMA: See Table A

TMA: See Table B

Selection:

Material of Body:
CF8M/CF8/CI/DI

Standards

- End dimensions acc. to DIN2633
- Inspection & test acc. to EN12266

Limitation

- Do not use EPDM when hydrocarbons are present.
- Kindly anticipate increased torque for PTFE coated disc + PTFE seat option; gear operation recommended for sizes $\geq 4"$.

2 Options

- Double "half pin" style available for increased performance and lifecycle
- Coated disc available in: rubber, PTFE, nylon

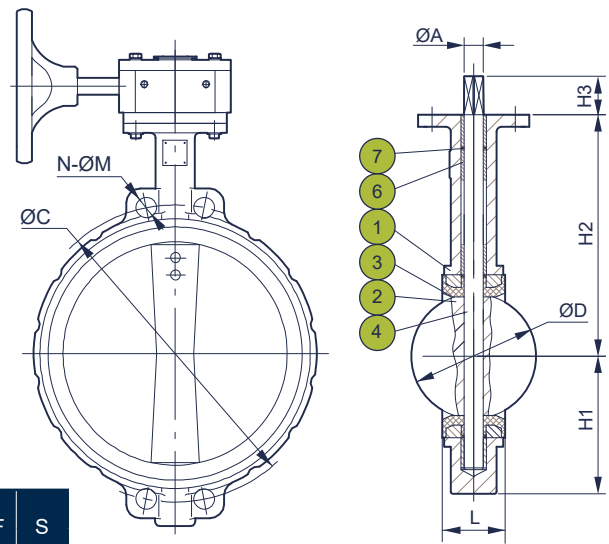
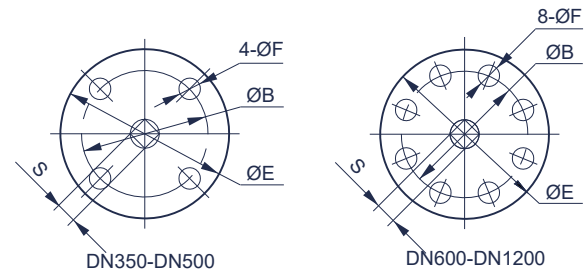

Materials List		
NO	PARTS NAME	MATERIAL
1	BODY	CF8M / CF8 / CI / DI
2	DISC*	CF8M / CF8 / CI / DI
3	SEAT	NBR / EPDM / VITON
4	STEM	SS410
5	TAPER PIN	SS
6	BUSHING	PTFE
7	O-RING	EPDM

*Coated disc option available.
Enclosed a condensed table, for complete options, contact DIE ERSTE directly.

Dimensions (mm)

Size		H1	H2	H3	L	ØD	ØC	N-ØM	ØA	ØE	ØB	ØF	S
IN	DN												
14"	350	267	368	45	80	333.3	460	16-Ø23	31.8	150	120	13	22
16"	400	298	400	51	90	389.6	515	16-Ø27	33.3	210	165	22	22
18"	450	318	422	51	109	439.9	565	20-Ø27	38	210	165	22	27
20"	500	349	479	64	135	491.6	620	20-Ø27	41	210	165	22	27
24"	600	410	562	70	156	592.3	725	20-Ø30	50	300	254	18	36
28"	700	520	624	72	169	694.1	840	24-Ø30	55	300	254	18	40
30"	750	516	624	72	175	744.2	-	-	55	300	254	18	40
32"	800	591	672	83	195	794.2	950	24-Ø33	55	300	254	18	40
36"	900	611	768	77	211	863.4	1050	28-Ø33	74	300	254	18	53
40"	1000	665	823	85	229	963.4	1160	28-Ø36	84	300	254	18	60
48"	1200	955	880	206	249	1185	1380	32-Ø39	92	350	298	22	60

Table B: Temperature Rating	
SEAT	APPLICABLE TEMPEPRATURE
NBR	-20°C to +80°C (-4°F to 176°F)
EPDM	-20°C to +120°C (-4°F to 248°F)
VITON	-10°C to +200°C (+14°F to 392°F)
PTFE	-20°C to +150°C (-4°F to 302°F)