

Concentric Butterfly Valve to DIN/EN Lug Type PN10, DN40 ~ DN500

Series 81L(E)-PN10

Features

- Suitable for use in HVAC, irrigation, industrial applications where positive shutoff is required
- Single through-put shaft provides most economical pricing
- 10 position lever or gear operation
- Alloy material available on request

PMA: See Table A

TMA: See Table B

Selection:

Material of Body:
CF8M/CF8/CI/DI

Standards

- End dimensions acc. to DIN2633
- Inspection & test acc. to EN12266

Limitation

- Do not use EPDM when hydrocarbons are present.
- Kindly anticipate increased torque for PTFE coated disc + PTFE seat option; gear operation recommended for sizes $\geq 4"$.
- End-of-line service at half rating

Options

- Double "half pin" style available for increased performance and lifecycle
- Coated disc available in: rubber, PTFE, nylon

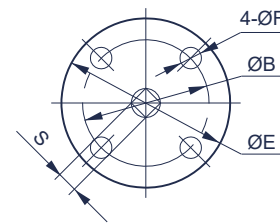

DN40-DN500

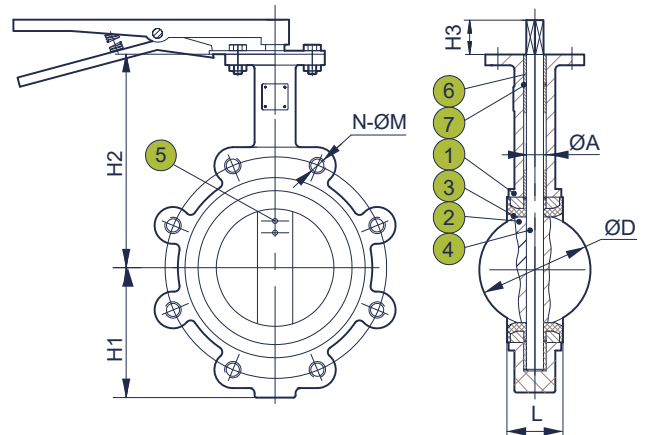

Materials List		
NO	PARTS NAME	MATERIAL
1	BODY	CF8M / CF8 / CI / DI
2	DISC*	CF8M / CF8 / CI / DI
3	SEAT	NBR / EPDM / VITON
4	STEM	SS410
5	TAPER PIN	SS
6	BUSHING	PTFE
7	O-RING	EPDM

*Coated disc option available.
Enclosed a condensed table, for complete options, contact DIE ERSTE directly.

Dimensions (mm)

Size IN DN	H1	H2	H3	L	ØD	ØC	N-ØM	ØA	S	ØE	ØB	ØF	
	1½"	40	70	110	32	35	42.4	110	4-M16	12.7	9	92	70
2"	50	76	162	32	45	52.9	125	4-M16	12.7	9	92	70	9
2½"	65	80	175	32	48	64.6	145	4-M16	12.7	9	92	70	9
3"	80	95	181	32	49	79.04	160	4-M16	12.7	9	92	70	9
4"	100	114	200	32	55	104.4	180	8-M16	15.8	11	92	70	9
5"	125	127	213	32	58	129.5	210	8-M16	19.05	14	92	70	9
6"	150	140	225	32	59	155.8	240	8-M20	19.05	14	92	70	9
8"	200	173	260	36	64	202.7	295	8-M20	22.2	17	125	102	11
10"	250	203	292	36	70	250.7	350	12-M20	28.6	22	125	102	11
12"	300	237	337	36	80	301.9	400	12-M20	31.8	22	150	125	13
14"	350	279	368	45	80	333.3	460	16-M20	31.8	22	150	125	13
16"	400	304	400	51	90	389.6	515	16-M20	33.3	22	210	165	22
18"	450	362	422	51	109	439.9	565	20-M24	38	27	210	165	22
20"	500	368	479	64	135	491.6	620	20-M24	41.15	27	210	165	22

Table B: Temperature Rating

SEAT	APPLICABLE TEMPERATURE
NBR	-20°C to +80°C (-4°F to 176°F)
EPDM	-20°C to +120°C (-4°F to 248°F)
VITON	-10°C to +200°C (+14°F to 392°F)
PTFE	-20°C to +150°C (-4°F to 302°F)

Concentric Butterfly Valve to DIN/EN Lug Type

PN10, DN600 ~ DN1000

Series 81L(E)-PN10

Features

- Suitable for use in HVAC, irrigation, industrial applications where positive shutoff is required
- Single through-put shaft provides most economical pricing
- 10 position lever or gear operation
- Alloy material available on request

PMA: See Table A

TMA: See Table B

Selection:

Material of Body:
CF8M/CF8/CI/DI

Standards

- End dimensions acc. to DIN2633
- Inspection & test acc. to EN12266

Limitation

- Do not use EPDM when hydrocarbons are present.
- Kindly anticipate increased torque for PTFE coated disc + PTFE seat option; gear operation recommended for sizes $\geq 4"$.
- End-of-line service at half rating

2

Options

- Double "half pin" style available for increased performance and lifecycle
- Coated disc available in: rubber, PTFE, nylon

Materials List		
NO	PARTS NAME	MATERIAL
1	BODY	CF8M / CF8 / CI / DI
2	DISC*	CF8M / CF8 / CI / DI
3	SEAT	NBR / EPDM / VITON
4	STEM	SS410
5	TAPER PIN	SS
6	BUSHING	PTFE
7	O-RING	EPDM

*Coated disc option available.
Enclosed a condensed table, for complete options, contact DIE ERSTE directly.

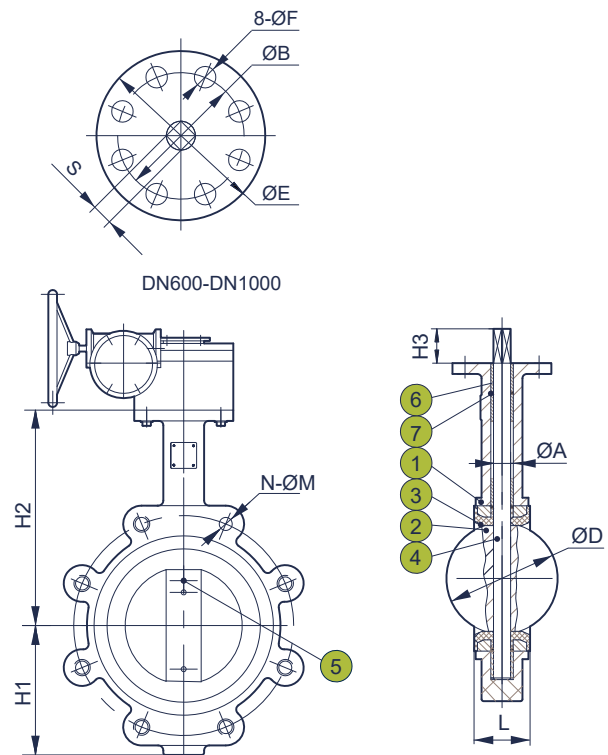

Dimensions (mm)

Size		H1	H2	H3	L	ØD	ØC	N-ØM	ØA	S	ØE	ØB	ØF
IN	DN												
24"	600	444	562	70	156	592.3	725	20-M27	50.65	36	300	254	18
28"	700	520	630	70	156	694.1	840	24-M27	63.35	40	300	254	18
30"	750	621	648	72	169	744.2	-	-	63.35	40	300	254	18
32"	800	590	690	72	169	794.2	950	24-M30	63.35	40	300	254	18
36"	900	623	768	77	211	863.4	1050	28-M30	74.25	53	300	254	18
40"	1000	670	850	77	211	963.4	1160	28-M33	84.2	60	300	254	18

Table A: Maximum Pressure Rating

SIZE	RUBBER SEAT	PTFE SEAT	PTFE SEAT+ PTFE COATED DISC
\leq DN150 (6")	13.7 bar (200psi)	13.7 bar (200psi)	10.3 bar (150 psi)
DN200 (8")	13.7 bar (200psi)	10.3 bar (150 psi)	10.3 bar (150 psi)
DN250 (10")~ DN300 (12")	13.7 bar (200psi)	10.3 bar (150 psi)	6.9 bar (100 psi)
DN350 (14")~ DN600 (24")	10.3 bar (150 psi)	6.9 bar (100 psi)	6.9 bar (100 psi)
\geq DN600 (24")	6.9 bar (100 psi)	-	-
Gear Operation Recommendation	≥ 300	\geq DN150	≥ 100

Table B: Temperature Rating

SEAT	APPLICABLE TEMPERATURE
NBR	-20°C to +80°C (-4°F to 176°F)
EPDM	-20°C to +120°C (-4°F to 248°F)
VITON	-10°C to +200°C (+14°F to 392°F)
PTFE	-20°C to +150°C (-4°F to 302°F)